

# ALPENINOX

## Pastry and Bakery Line 3 Door Refrigerated Counter, -2°/+7°C, 600X400 grid

ITEM # \_\_\_\_\_

MODEL # \_\_\_\_\_

NAME # \_\_\_\_\_

SIS # \_\_\_\_\_

AIA # \_\_\_\_\_

ALPENINOX

Pastry and Bakery Line  
3 Door Refrigerated Counter, -2°/+7°C, 600X400 grid

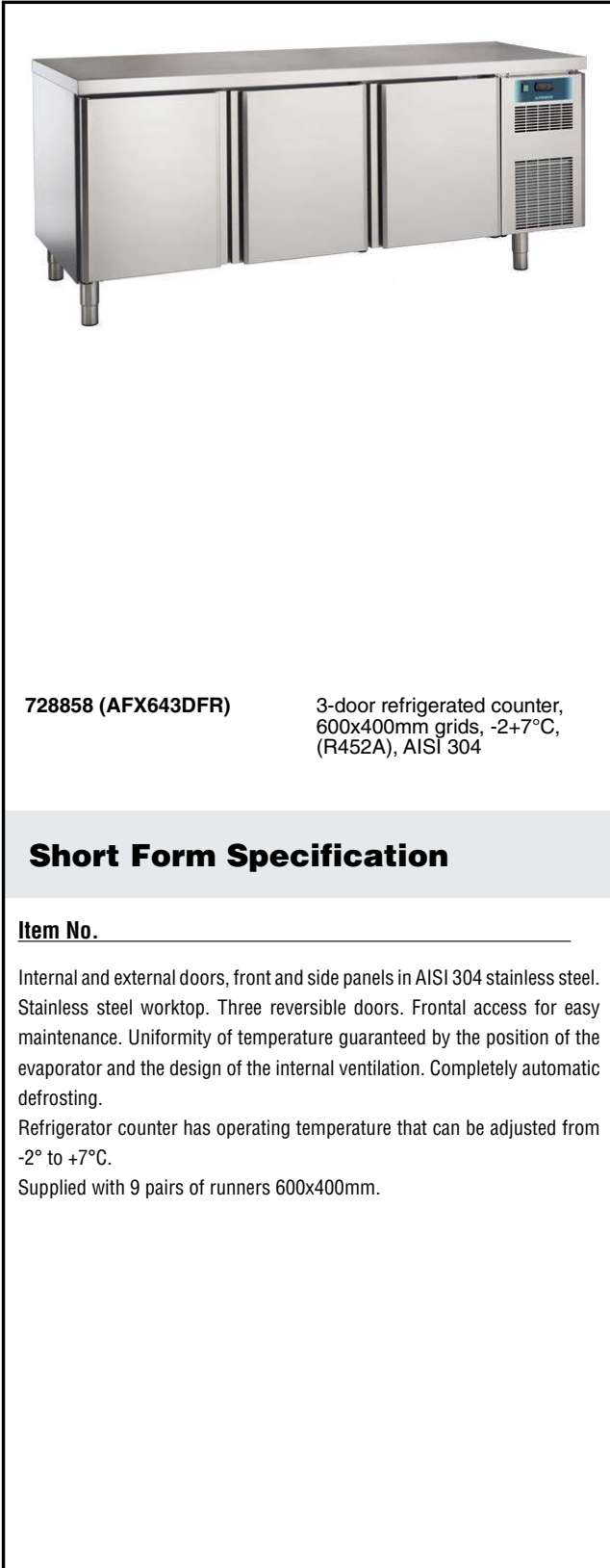

728858 (AFX643DFR)

3-door refrigerated counter,  
600x400mm grids, -2+7°C,  
(R452A), AISI 304

### Short Form Specification

Item No. \_\_\_\_\_

Internal and external doors, front and side panels in AISI 304 stainless steel. Stainless steel worktop. Three reversible doors. Frontal access for easy maintenance. Uniformity of temperature guaranteed by the position of the evaporator and the design of the internal ventilation. Completely automatic defrosting.

Refrigerator counter has operating temperature that can be adjusted from -2° to +7°C.

Supplied with 9 pairs of runners 600x400mm.

### Main Features

- Frontal access for easy maintenance.
- Pressed stainless steel door handle without joints gathering dust and dirt.
- Completely automatic defrosting.
- Automatic evaporation of the defrosting water by heating element.
- Adjustable temperature range from -2°C to +7°C.
- Suitable for use in ambient temperature of up to 40°C (climatic class 5).
- Large digital digit display with cabinet temperature display and setting.
- Internal runners removable without any tools for faster cleaning operations.

### Construction

- On site reversible left/right doors.
- Stainless steel AISI 304 inside and outside (except back panel).
- Insulation thickness: 50 mm wall insulation.
- 3 compartments with 3 doors.
- The position of the evaporator and the design of the internal ventilation facilitate the uniformity of the temperature.
- Environmentally friendly: R452a as refrigerant gas.

### Included Accessories

- 9 of Pair of L runner, 600x400mm PNC 728874

### Optional Accessories

- Pair of L runner, 600x400mm PNC 728874
  - Stainless steel grid, 600x400mm PNC 728876
- for pastry counters

APPROVAL: \_\_\_\_\_

## Pastry and Bakery Line 3 Door Refrigerated Counter, -2°/+7°C, 600X400 grid

**Front**

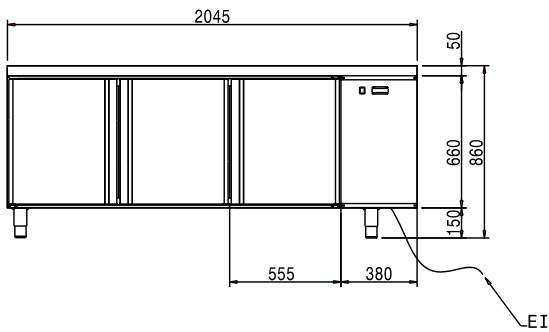

**Side**

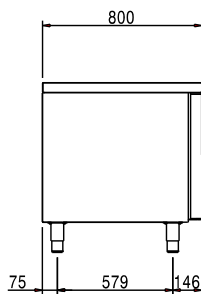

EI = Electrical inlet (power)

**Top**

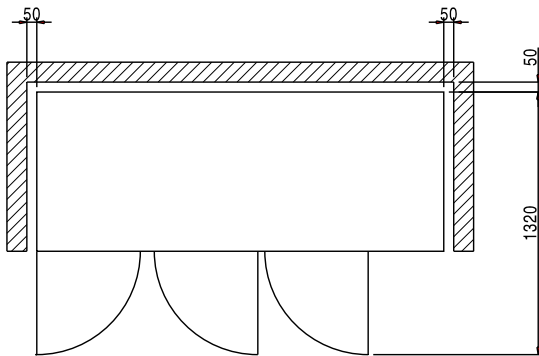

### Electric

Supply voltage:

728858 (AFX643DFR) 230 V/1N ph/50 Hz

Electrical power max.:

0.28 kW

### Key Information:

Gross capacity:

510 lt

N° of doors:

3

Door hinges:

2 Right

External dimensions, Width:

2045 mm

External dimensions, Depth:

800 mm

External dimensions, Depth with  
Doors Open:

1320 mm

External dimensions, Height:

860 mm

Type of external material:

Stainless Steel AISI 304 Scotch  
Brite

Type of internal material:

304 AISI

Internal side panels material:

304 AISI

### Refrigeration Data

Control type:

Electronic

Refrigerant type:

R452A

GWP Index:

2141

Refrigeration power at  
evaporation temperature:

-10 °C

Operating temperature min.:

-2 °C

Operating temperature max.:

10 °C

### Product Information (EU Regulation 2015/1094)

Type of model:

counter chilled

### EU energy labelling from 1st July 2016

The European energy labelling scheme for professional refrigerators and freezers is based on requirements setting Minimum Energy Performance standards for commercial refrigeration cabinets sold within the EU. These requirements are designed to drive energy efficiency and environmentally friendly approach for professionals. The European energy labelling scheme will apply to all manufacturers and importers who sell and market products within the EU and it is mandatory across Europe. Important: all products which consume energy above the minimum level will not be able to be sold within the EU from 1 July 2016.

SI 2020 No. 1528.

Important: all products which consume energy above the minimum level will not be able to be sold within the EU from 1 July 2016.

